

ISOMETER[®] isoPV1685DP

Insulation monitoring device
for unearthed photovoltaic systems

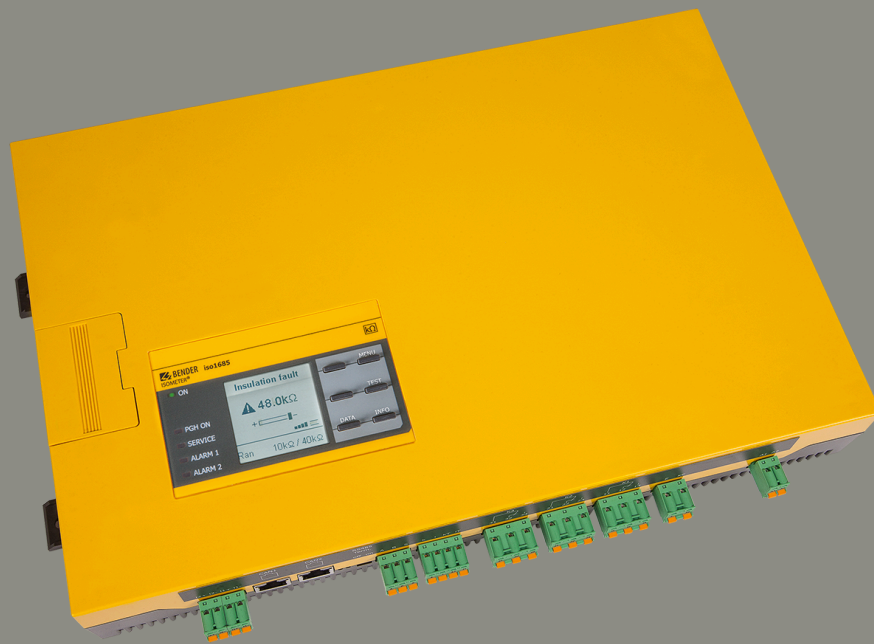

Image similar



Intended use

The device isoPV1685DP is used for insulation monitoring of large photovoltaic systems up to AC 1000 V and DC 1500 V designed as IT systems. The measurement method specially developed for slow voltage fluctuations (MPP tracking) monitors the insulation resistance even in systems equipped with large solar generator panels where extremely high system leakage capacitances against earth exist due to interference suppression methods. Adaptation to system-related high leakage capacitances also occurs automatically within the selected profile.

Another area of application is in battery energy storage systems (BESS). Two profiles are available for this purpose, which are specially designed to meet the requirements of these applications.

The device generates locating current pulses required for insulation fault location. That allows the localisation of the insulation fault using permanently installed or mobile insulation fault locators.

In order to meet the requirements of the applicable standards, customised parameter settings must be made on the equipment in order to adapt it to local equipment and operating conditions. Please heed the limits of the range of application indicated in the technical data.

Intended use also includes

- the observation of all information in the manual and
- compliance with the test intervals in accordance with the relevant standards and operating rules.

Caution: This equipment is not intended for use in residential environments and may not provide adequate protection to radio reception in such environments.

Do not make any unauthorised changes to the device. Only use spare parts and optional accessories sold or recommended by the manufacturer.

Any other use than that described in this manual is regarded as improper.

Functional description

Insulation monitoring is carried out using an active measuring pulse which is superimposed onto the IT system to earth via the integrated coupling. If the insulation resistance between a PV system and earth falls below the set prewarning response value R_{an1} , the LED **ALARM 1** lights up and relay **K1** switches. If the insulation resistance falls below the alarm response value R_{an2} , the LED **ALARM 2** lights up and the alarm relay **K2** switches. The relay **K3** switches in case of device or connection failures.

When starting the insulation fault location, the LED **PGH ON** signals the locating current pulse.



Installation inside a control cabinet

If the ISOMETER® is installed inside a control cabinet, the insulation fault message must be audible and/or visible to attract attention.

IT systems with several ISOMETER®s

Only one ISOMETER® may be connected in a galvanically connected system. In IT systems that are interconnected via tie switches, ISOMETER®s that are not required must be disconnected from the IT system or switched to inactive.

If IT systems are coupled via capacitors or diodes, a central control of the various ISOMETER® must be used.

Prevent measurement errors!

In galvanically coupled DC circuits, an insulation fault can only be detected correctly if a minimum current of > 10 mA flows through the rectifiers.

Unspecified frequency range

Depending on the application and the selected measurement profile, continuous insulation monitoring is also possible in low frequency ranges. For IT systems with frequency components above the specified frequency range, there is no influence on the insulation monitoring.

Device features

ISOMETER® for photovoltaic systems.

Measuring

- Insulation monitoring of large PV systems
- Automatic adjustment to high system leakage capacitances
- Combination of **AMP^{PLUS}** and other profile-specific measurement methods
- Separately adjustable response values R_{an1} (Alarm 1) and R_{an2} (Alarm 2) for prewarning and alarm
- Connection monitoring of E/KE

Device

- Device self test with automatic alarm message in the event of a fault
- History memory with real-time clock (buffer for 30 days) for storing 1023 alarm messages with date and time
- Freely programmable digital inputs/outputs
- Separate relays for insulation fault 1, insulation fault 2 and device error

Display

- High-resolution graphic LC display for excellent readability and recording of the device status
- Graphical representation of the insulation resistance over time (isoGraph)

Interfaces

- RS-485 interface for data exchange with other Bender devices
- Remote setting of certain parameters via the Internet (COMTRAXX® gateway)
- Remote diagnosis by the Bender service via the Internet
- BMS bus via RS-485 interface

Insulation fault monitoring

- Integrated locating current injector up to 50 mA for insulation fault location
- Display of insulation faults selectively located by EDS systems
- Parameter setting of EDS systems

Product description

The ISOMETER® isoPV1685DP is an insulation monitoring device for IT systems according to IEC 61557-8 and -9. It can be used in photovoltaic systems. Please refer to the technical data for the exact device specification.

The isoPV1685DP generates locating current pulses required for insulation fault location. That allows the localisation of the insulation fault using permanently installed or mobile insulation fault locators.

The measurement method especially developed for this purpose monitors the insulation resistance even in installations where extremely high system leakage capacitances against earth exist due to interference suppression methods. The adaptation even to system-related high leakage capacitances is automatic.

Wiring diagram

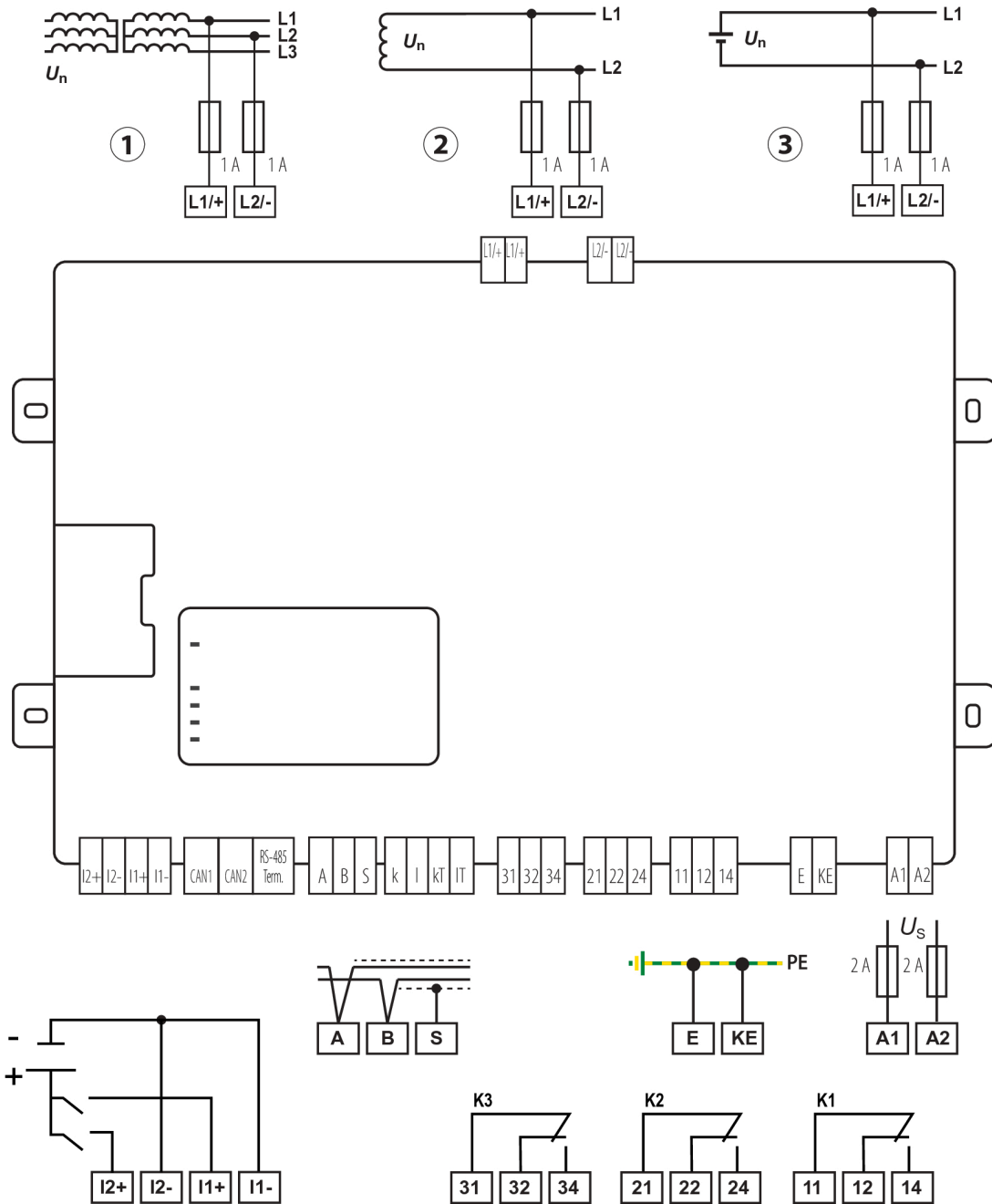

I2+, I2-	Digital input: no function
I1+, I1-	Digital input: Start insulation fault location in manual mode
CAN1, CAN2	No function
RS485 Term. off / on	RS-485 termination
A, B, S	RS-485 bus connection (A, B) BMS protocol: PE potential, connect one end of shield (S)
k, I, kT, IT	no function
31, 32, 34	Relay output for internal device errors (LED SERVICE)

21, 22, 24	Relay output for alarm insulation faults (LED ALARM 2)
11, 12, 14	Relay output for prewarning insulation faults (LED ALARM 1)
E, KE	Separate connection of E (earth) and KE (reference) to PE
A1, A2	Connection to supply voltage (via fuses, 2 A each)
L1/+	Connection to L1/+ of the IT system via 1 A fuse
L2/-	Connection to L2/- of the IT system via 1 A fuse

Device profiles

The adaptation to different applications is achieved by selecting a device profile. The following device profiles are available.

PV up to 500 µF

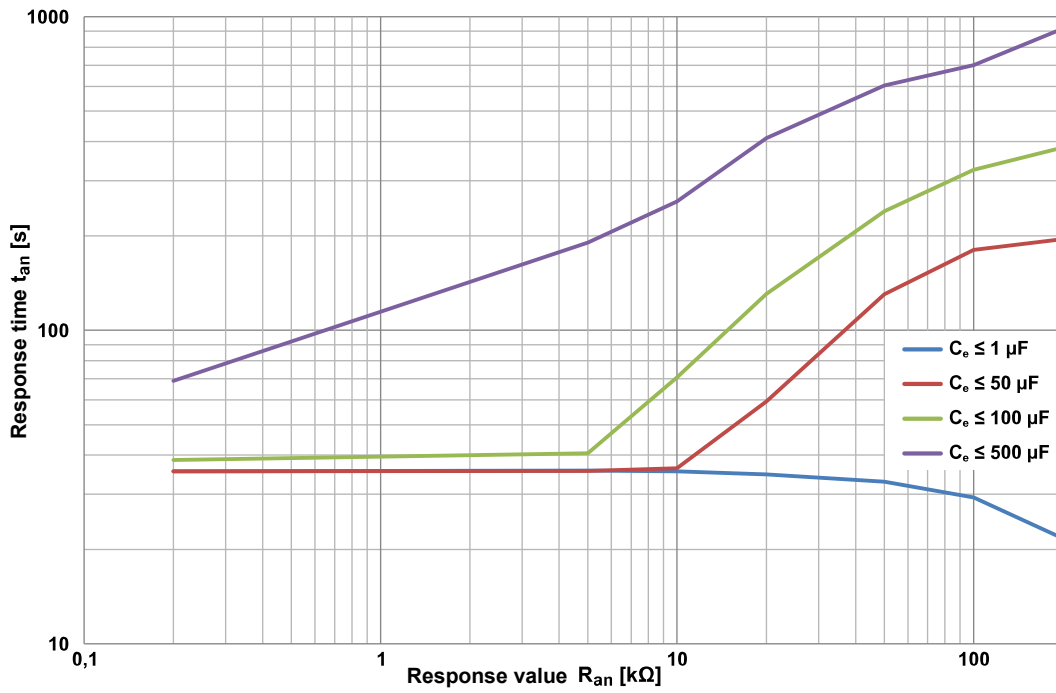

PV up to 4000 µF

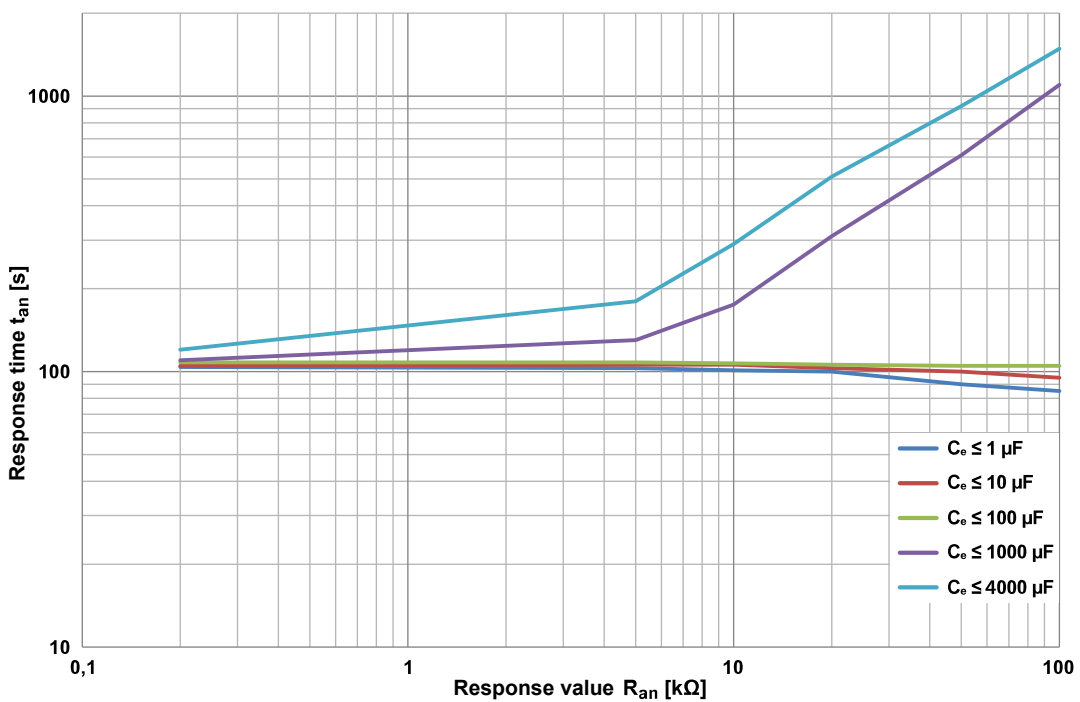

BESS up to 10 MΩ

Profile for battery energy storage systems (BESS) with a high insulation level of up to 10 MΩ. Specially designed for DC networks with AC components.

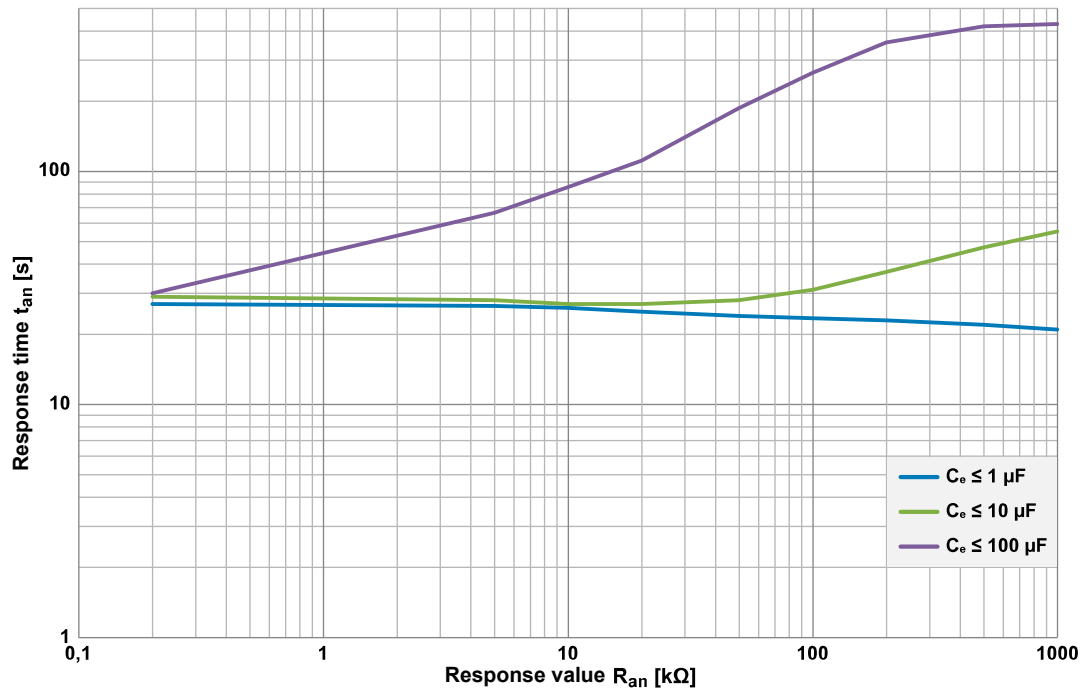

BESS up to 4000 μF

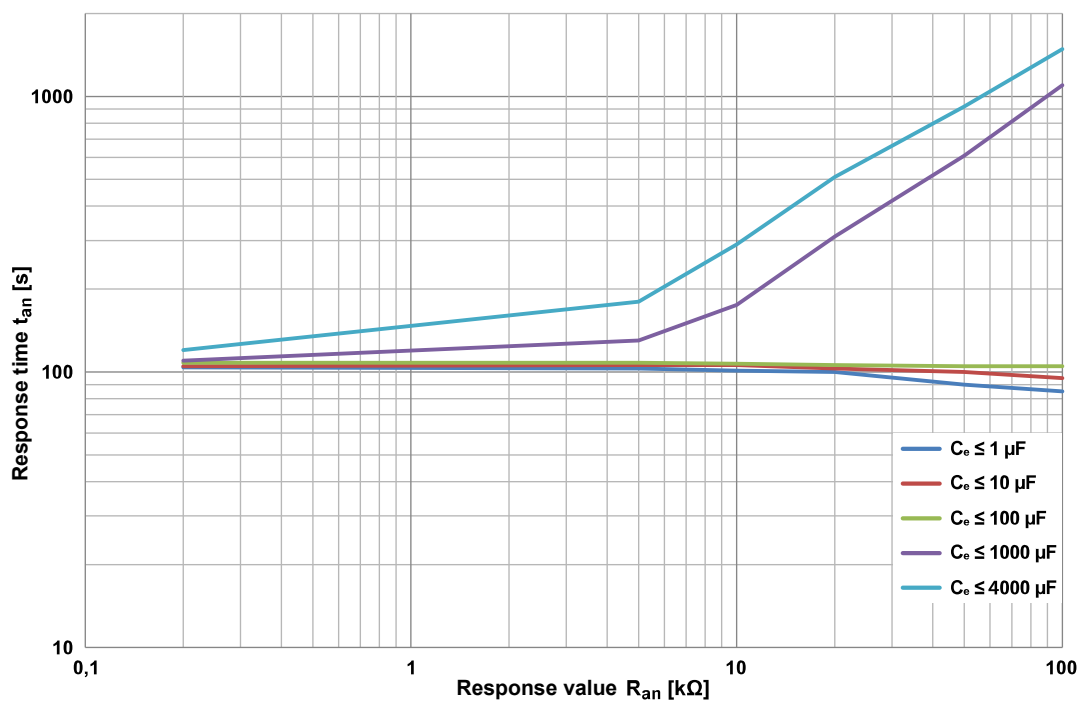

Leakage capacitance diagram

The determination of the leakage capacitance depends on the size of the insulation resistance. The following diagrams show the relationship

Example:

Insulation resistance 50 kΩ => min. measurable leakage capacitance 35 μF

Insulation resistance 5 kΩ => min. measurable leakage capacitance 210 μF

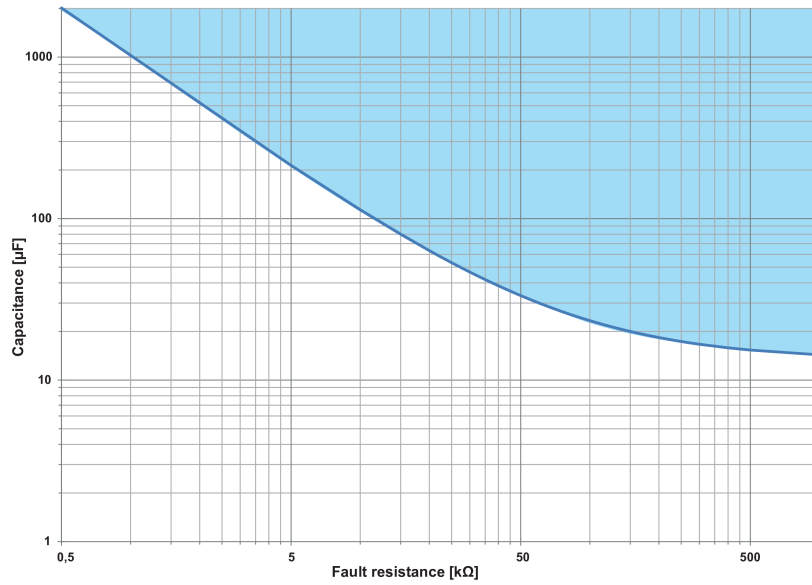

Technical data

Insulation coordination acc. to IEC 60664-1/IEC 60664-3

Definitions

Measuring circuit (IC1)	(L1/+, L2/-), (E, KE)
Supply circuit (IC2)	A1, A2
Output circuit 1 (IC3)	11, 12, 14
Output circuit 2 (IC4)	21, 22, 24
Output circuit 3 (IC5)	31, 32, 34
Control circuit (IC6)	(A, B), (I1+, I1-, I2+, I2-)
Rated voltage	DC 1500 V
Overvoltage category (OVC)	III

Rated impulse voltage

IC1 / (IC2-5)	10 kV
IC2 / (IC3-5)	4 kV
IC2 / IC1+IC6	0.8 kV
IC3 / (IC4-6)	4 kV
IC4 / (IC5-6)	4 kV
IC5 / IC6	4 kV

Rated insulation voltage

IC1 / (IC2-5)	1500 V
IC2 / (IC3-5)	250 V
IC2 / IC1+IC6	50 V
IC3 / (IC4-6)	250 V
IC4 / (IC5-6)	250 V
IC5 / IC6	250 V
Pollution degree	3

Safe isolation (reinforced insulation) between

IC1 / (IC2-5)	OVC III, 1500 V
IC2 / (IC3-5)	OVC III, 300 V
IC2 / IC1+IC6	OVC III, 50 V
IC3 / (IC4-6)	OVC III, 300 V
IC4 / (IC5-6)	OVC III, 300 V
IC5 / IC6	OVC III, 300 V

Voltage test (routine test) acc. to IEC61010-1

IC1 / (IC2-5)	AC 2.2 kV
IC2 / IC6	DC ±0.5 kV
IC3 / (IC4-6)	AC 2.2 kV
IC4 / (IC5-6)	AC 2.2 kV
IC5 / IC6	AC 2.2 kV

Supply voltage

Supply voltage U_s	DC 18...30 V
Power consumption	≤ 9 W

Voltage range of the system to be monitored

Nominal system voltage range U_n	AC 0...1000 V; DC 0...1500 V
Frequency range f_n	DC; 50 Hz; 60 Hz (±1 Hz)
Tolerance of U_n	AC +10 %; DC +5 %

Measuring circuit for insulation monitoring

Measuring voltage U_m (peak)	± 50 V
Measuring current I_m (at $R_F = 0 \Omega$)	≤ 0.7 mA
Internal DC resistance R_i	≥ 70 kΩ
Impedance Z_i at 50 Hz	≥ 70 kΩ
Permissible extraneous DC voltage U_{ig}	≤ 1600 V
Permissible system leakage capacitance C_e (profile-dependent)	0...4000 μF

Response values for insulation monitoring

Response values R_{an} (profile-dependent)	200 Ω ... 200 kΩ
Condition for response values R_{an1} and R_{an2}	$R_{an1} \geq R_{an2}$
Obere Messbereichsgrenze bei Einstellung $C_{emax} = 500 \mu F$	200 kΩ
Upper limit of the measuring range for setting $C_{emax} = 4000 \mu F$	50 kΩ
Relative uncertainty (acc. to IEC 61557-8)	
10...200 kΩ	±15 %
0.2 kΩ... < 10 kΩ	±200 Ω ±15 %
Response time t_{an} at $R_F = 0.5 \times R_{an}$ ($R_{an} = 10 \text{ k}\Omega$) and $C_e = 1 \mu F$ (acc. to IEC 61557-8)	profile-dependent, typ. 10 s
Hysteresis	25 %, +1 kΩ

Measuring circuit for insulation fault location (EDS)

Locating current I_L	DC ≤ 50 mA
Test cycle / pause	2 s / 4 s

Display

Indicator LEDs for alarms and operating states	1 × green, 4 × yellow
Display	Grafic display 127 × 127 pixel, 40 × 40 mm
Display range measured value (profile-dependent)	200 Ω ... 200 kΩ

Inputs

Operating mode	active high, active low
Functions	off, test, reset, deactivate device, insulation fault location
High level	10...30 V
Low level	0...0.5 V

Serial interface

Interface	RS-485
Protocols	BMS; Modbus RTU
Connection	Terminals A/B Shield: terminal S
Cable length	≤ 1200 m
Shielded cable (shield to functional earth on one end)	2-core, ≥ 0.6 mm ² , z. B. J-Y(St)Y 2x0.6
Terminating resistor, can be connected (Term. RS-485)	120 Ω (0.5 W)
Device address, BMS bus	2...90
Device address, Modbus RTU	1...247
Baud rate	9.6 / 19.2 / 38.4 / 57.6 / 115 kB
Parity	even / odd
Stop bits	1 / 2 / auto

Switching elements

Switching elements	3 changeover contacts:
K1	Insulation fault alarm 1
K2	Insulation fault alarm 2
K3	Device error
Operating principle K1, K2	n/c operation; n/o operation
Operating principle K3	n/c operation
Electrical endurance under rated operating conditions	100,000 cycles

Contact data acc. to IEC 60947-5-1:

Utilisation category	AC-13 / AC-14 / DC-12 / DC-12 / DC-12
Rated operational voltage	230 V / 230 V / 24 V / 110 V / 220 V
Rated operational current	5 A / 3 A / 1 A / 0.2 A / 0.1 A
Minimum contact rating	1 mA bei AC/DC ≥ 10 V

Connection (except mains connection)

Connection type	pluggable push-wire terminals
Connection, rigid/flexible	0.2...2.5 mm ² / 0.2...2.5 mm ²
Connection, flexible with ferrule, without/with plastic sleeve	0.25...2.5 mm ²
Conductor sizes (AWG)	24...12

Mains connection

Connection type	pluggable push-wire terminals
Connection, rigid/flexible	0.2...10 mm ² / 0.2...6 mm ²
Connection, flexible with ferrule, without/with plastic sleeve	0.25...6 mm ² / 0.25...4 mm ²
Conductor sizes (AWG)	24...8
Stripping length	15 mm
Opening force	90...120 N

Environment / EMC

EMC	IEC 61326-2-4
Rel. humidity	10...100 %
Area of application	≤ 3000 m NN

Ambient temperature

Stationary use	-40...+70 °C
Transport	-40...+80 °C
Long-term storage	-25...+80 °C

Classification of climatic conditions acc. to IEC 60721:

Stationary use (IEC 60721-3-3)	3K22
Transport (IEC 60721-3-2)	2K11
Long-term storage (IEC 60721-3-1)	1K22

Classification of mechanical conditions acc. to IEC 60721:

Stationary use (IEC 60721-3-3)	3M11
Transport (IEC 60721-3-2)	2M4
Long-term storage (IEC 60721-3-1)	1M12

Other

Operating mode	continuous operation
Position of normal use	vertical, mains connection on top
Tightening torque for enclosure mounting (4x M5)	1.0...1.5 Nm
Degree of protection, internal components	IP30
Degree of protection, terminals	IP30
Enclosure material	polycarbonate
Flammability class	V-0
Software version	
Weight	≤ 1600 g

Standards and approvals

The ISOMETER® isoPV1685DP was developed in compliance with the following standards:

- DIN EN 60664-1 (VDE 0110-1)
- DIN EN 61557-8 (VDE 0413-8)
- DIN EN 61557-9 (VDE 0413-9)
- IEC 61326-2-4
- IEC 61557-8
- IEC 61557-8 Appendix C
- IEC 61557-9



Ordering details

Model	Response value	Nom. system voltage	Supply voltage	Art. No.
isoPV1685DP-425	200 Ω ... 200 k Ω	AC 0 ... 1000 V DC 0 ... 1500 V	DC 24 V \pm 25%	B91065808

Dimensions

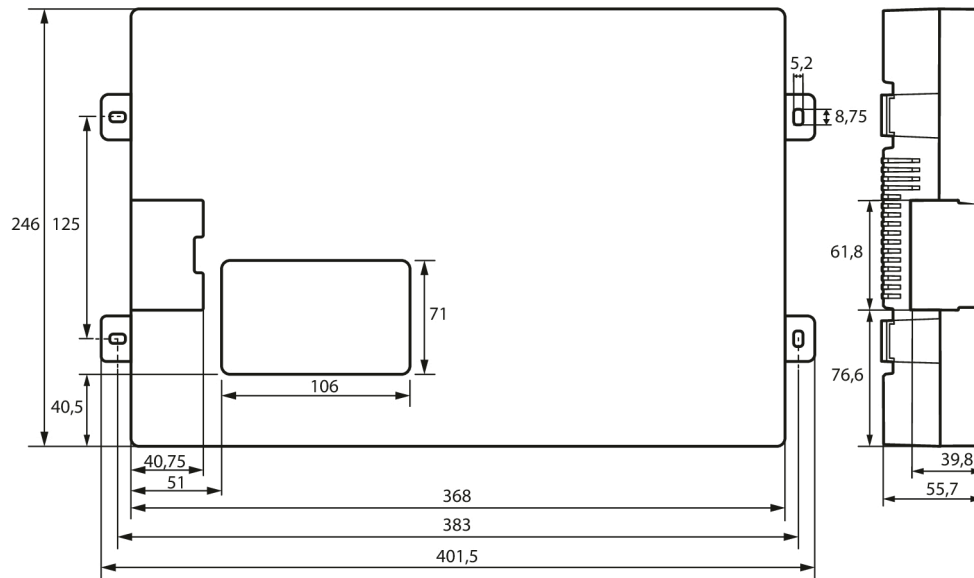

Dimensions in mm



Bender GmbH & Co. KG

Londorfer Straße 65
35305 Grünberg
Germany

Tel.: +49 6401 807-0
info@bender.de
www.bender.de



© Bender GmbH & Co. KG, Germany
Subject to change!
The specified standards take into account the
edition valid until 04.2026 unless otherwise
indicated.